

Jooby Indoor Gateway LoRaWAN



jooby

Technical specifications

Gateway for data collection in LoRaWAN networks

Part number: Jooby Indoor Gateway LoRaWAN 501 EU
Jooby Indoor Gateway LoRaWAN 502 EU

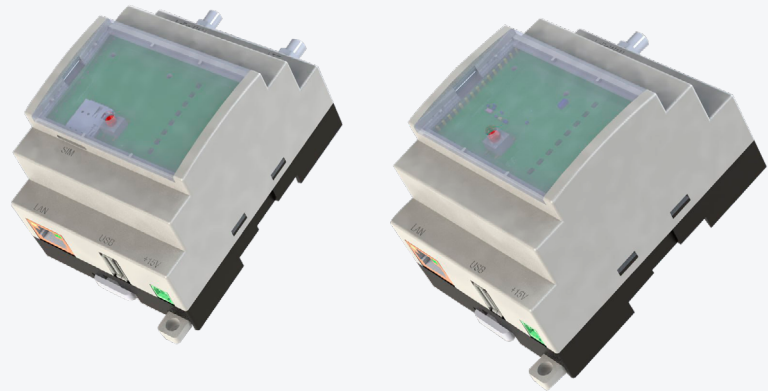

Jooby Indoor Gateway LoRaWAN devices are intended for receiving radio module data and transmitting it to the server. Data is transmitted through the LoRaWAN wireless network. The gateway sends data to the server, where it is converted and stored in the software as user-friendly reports.

The gateways have industrial-grade components that ensure reliable data protection. They are easy to use, owing to a set of accessories and fixtures. The functionality of the gateways can be expanded through optional technical solutions, which can be included at the customer's request.

Specifications

Equipment

A **plastic case** with all necessary cable inputs

LoRaWAN concentrator: one module by default for a maximum of **8 channels**

GNSS (optional)

Data transmit: LTE and Ethernet

Indoor device with extended operating temperature range, **Outdoor mounting** can be done inside an hermetic electrical cabinet only

Power supply: Ethernet (802.3af) with overvoltage and lightning protection

LTE (depending on device model)

Software

Web UI

Technical specifications

Overview

This overview covers the triple control module for the Jooby Indoor Gateway LoRaWAN, which includes the mainboard (JOGLS_CPU), interface board (JOGLS_RS-485) and indication board (JOGLS_LED). This section also provides a list of components and accessories for the Jooby Indoor Gateway LoRaWAN.

Components and accessories

The Jooby Indoor Gateway LoRaWAN has a number of components supplied with the device, as well as other accessories which can be ordered additionally:

- Triple control module: main board, interface board, and indication board
- Enclosure
- Accessories

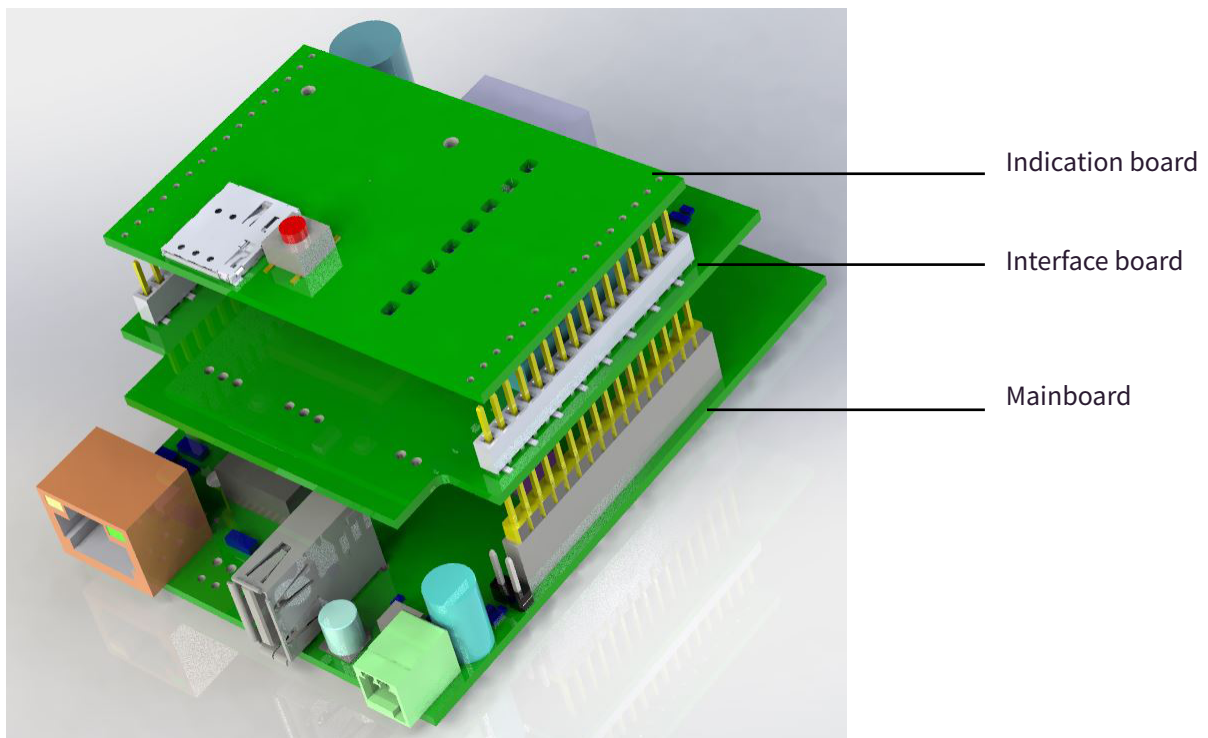

Figure 1: Triple control module (model 501 EU is shown)

Mainboard (JOGLS_CPU)

CPU:	JOGLS mainboard with Arm Cortex-A7 STM32MP131FAF7 (up to 1 GHz)
RAM:	DDR3-1066 512 MB
Flash memory:	8 GB eMMc (16 GB eMMc – optionally)
Tx power:	up to 22 dBm
Rx sensitivity:	up to -111 dBm
LoRaWAN concentrator:	one module for a maximum of 8 channels in standard package
LTE (depending on device model):	LTE (1 SIM card, Quectel EG915N - LTE-FDD (B1/B3/B7/B8/B20), GSM (EGSM900/DCS1800)
GNSS (optional):	LTE EG915N integrated module or GNSS standalone module (GPS/GLONASS/Galileo/BDS/QZSS/SBAS) (on request)
Tampers (optional):	up to 2 pcs
Real time clock (RTC)	✓
Power supply over Ethernet (PoE):	basic Ethernet network as per IEEE 802.3u 100Base-TX standard (fast Ethernet network)
External Power supply:	DC 12-16,5V (15V+/-10% is needed for charge pump system if available)

Interface board (JOGLS_RS-485)

RS-485 (optional):	2 pcs max.
Backup power supply — charge pump (optional):	connection to external battery of reserve power supply

Indication board (JOGLS_LED)

Indicators:	Indicators: a maximum of 8 LED indicators displaying the operation of various nodes within the triple control module
Functional button (Fn)	✓
Backup real-time-clock battery (optional)	CR2032 lithium-ion battery

Enclosure

Case:	light gray V0 UL-94 plastic (flame-retardant)
Interface:	1 or 2 SMA connectors for external antennas, 1 Ethernet/PoE port, USB 2.0, LTE antenna (depending on device modification), LoRaWAN antenna
Weight:	approximately 0.16 kg
Dimensions:	107 mm x 70 mm x 59 mm
Installation:	the case design allows for DIN rail mounting as well as installation on flat surfaces using sliding strips and screws for fastening

Accessories (included)

LoRaWAN antenna (various design versions and cable lengths available on request)
LTE antenna (depends on device modification)
External power supply (on request)



Figure 2: Accessories (included, depending on device modification) LTE and LoRaWAN antenna

Hardware

The hardware specifications provide a description of the Jooby Indoor Gateway LoRaWAN interfaces, covering both the hardware interfaces and the triple control module interface.

Hardware interfaces

The image below shows the hardware interfaces of the Jooby Indoor Gateway LoRaWAN.

Jooby Indoor Gateway LoRaWAN 501 EU

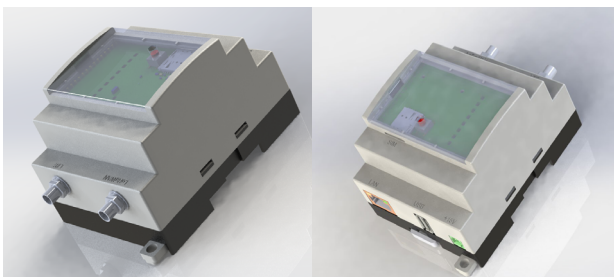

Jooby Indoor Gateway LoRaWAN 502 EU

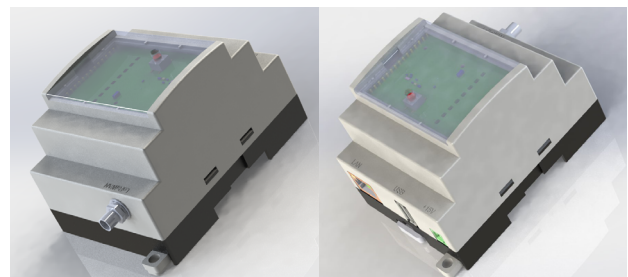

Figure 3: Hardware interfaces

Control module interfaces

Mainboard Interfaces

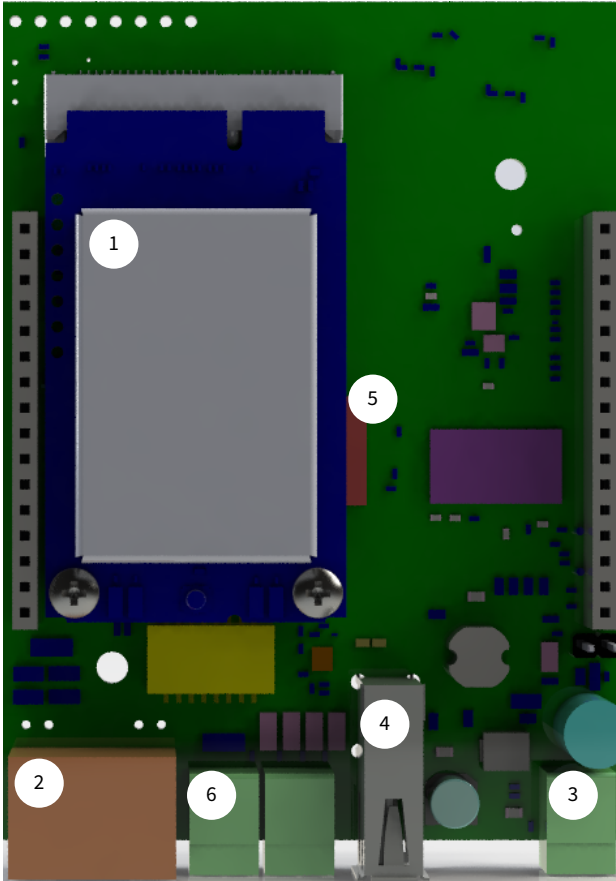

Figure 4.1. Mainboard

Description of Figure 4.1:

1. Mini PCIe Card LoRaWAN Concentrator
2. Ethernet / PoE
3. Power connector DC 12-16.5V (15+/-10%V is needed for charge pump system if available)
4. USB 2.0
5. CPU
6. Tamper (up to 2 pcs, optional)

Interface board

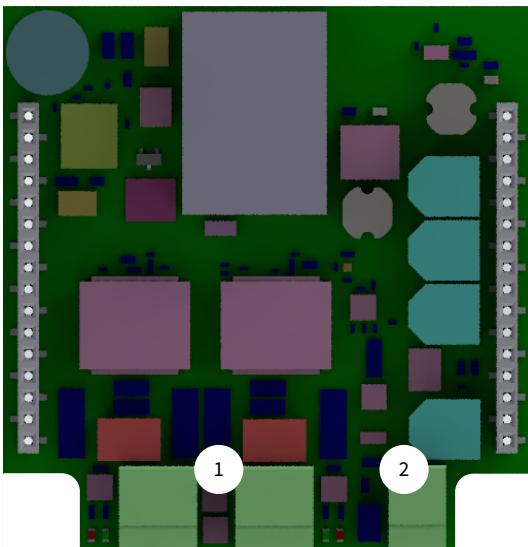

Figure 4.2. Interface board

Description of Figure 4.2:

1. RS-485 interfaces (up to 2 pcs, optional)
2. Backup Battery connector (optional)

Indication board interfaces

The indication board features the Functional button (Fn) and up to 8 x LED indicators displaying the device status.

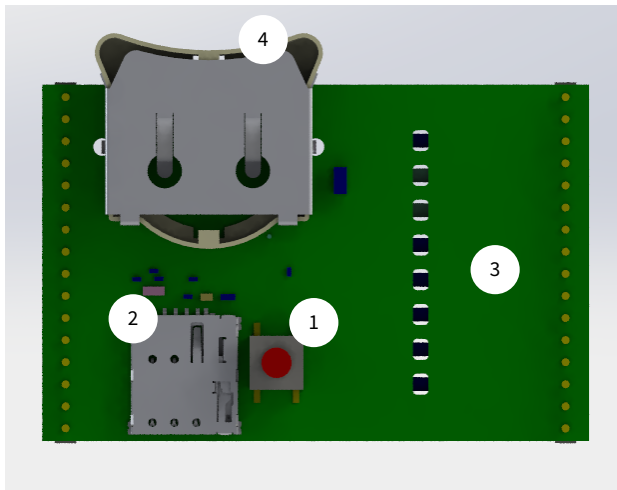

Figure 4.3. Indication board

Description of Figure 4.3:

1. Functional button (Fn)

- **Factory reset:**

- hold for 30 sec until the System indicator flashes red
- Release the Fn button and **wait for 30 sec** after the System|Status indicator turns red
- once the System indicator starts flashing in yellow, **hold the button for 30 sec**
- after the System and System|Alarm indicators turn red, **release Fn button**
- the gateway is now reset successfully.

- **Switching of memory bank:**

- insert the flash drive into the USB port
- **hold for 30 sec** until the System indicator flashes red
- Release the Fn button and **wait for 30 sec** after the System indicator turns red
- once the System indicator starts flashing yellow, **hold the button for 15 sec**
- after the System indicator turns red, **release Fn button**
- the gateway will boot from flash memory.

2. Nano SIM card slot (depends on the device model)

3. LED indicators

4. RTC backup battery holder (on request)

LED indicator status is described as shown below. Please see the text printed next to each LED indicator on the Indication board.

POWER

LED indicator name	Function	Colour
POWER	Availability of PoE / DC power supply	Green
BAT	Backup battery status	Charging – red Charged – green

SYSTEM

LED indicator name	Function	Colour
SYSTEM	Gateway operation	Normal operation / Loaded successfully—green Error—red
ALARM	Tamper detector disconnected—the device has been opened	Normal operation / Loaded successfully – green Error / Standby mode – red

LTE

LED indicator name	Function	Colour
NET	Network availability	Green

LAN

LED indicator name	Function	Colour
Link/Activity	Connection/Activity	Yellow

LoRaWAN

LED indicator name	Function	Colour
LoRa_NET	Server connection established	Blue
WLAN*	Wi-Fi network available	Green
RS485*	Illumination of RS485 connector as part of the JOGLS_RS-485 Interface board (Optional)	Green—connected / active Red—receive / transmit Off—inactive

*optional, if exist in the control module

Models

The table below shows the main models of the Jooby Indoor Gateway LoRaWAN and Mainboard configurations.

Jooby Indoor Gateway LoRaWAN (followed by model number)

Model	Mainboard configuration	8 LoRaWAN channels	Overvoltage protection	Lightning protection	LTE	EU868, US915
501EU	C001E1W0L1G00A00000	✓	✓	✓	✓	✓
502EU	C001E1W0L1G00A00000	✓	✓	✓		✓

Certification



Technical description

Main specifications (standard models)

Function	Technical specifications
CPU	Arm Cortex-A7, DDR3 RAM 512 MB, 8 GB eMMC (optionally 16 GB eMMC)
LoRaWAN	<ul style="list-style-type: none"> • Module: SX1302 or SX1303 Mini PCIe • Channels: up to 8 channels • RX sensitivity: Standard sensitivity (EU868/US915): -141 dBm with SF12 bandwidth of 125 kHz -127 dBm with SF7 bandwidth of 125 kHz -111 dBm with FSK bandwidth of 50 kbps • TX power: 22dBm (max) • Frequency: EU868, US915, if requested—AS923, AU915, KR920, IN865
LTE	Supports Quectel EG915N - LTE-FDD(B1/B3/B7/B8/B20), GSM (EGSM900/DCS1800)

Main specifications (standard models)

Function	Technical specifications
Power supply	PoE (IEEE 802.3af/at compatible) - 42~57V DC DC 12-16,5V (15V+/-10% is needed for charge pump system if available)
Power consumption	10 W (max)
Ethernet	RJ45 (10/100 Mbps) with overvoltage and lightning protection
Antenna	SMA connector
Case material	ABS, V0 UL-94
Weight	~ 0.16 kg
Dimensions	107 mm x 70 mm x 59 mm
Operating temperature	From -40 °C to +60 °C
Storage temperature	From -40 °C to +85 °C
Operating humidity	From 0% to 95% (operates without condensation)
Allowable humidity during storage	From 0% to 95% (operates without condensation)

Radio frequency specifications LoRaWAN

Function	Specifications
Operating frequency	<ul style="list-style-type: none"> • EU868, US915 • on request—AS923, AU915, KR920, IN865
Radiated power	22 dBm (max)
Receiver sensitivity	Standard sensitivity (EU868/US915): <ul style="list-style-type: none"> • 141 dBm with SF12 bandwidth of 125 kHz • 127 dBm with SF7 bandwidth of 125 kHz • 111 dBm with FSK bandwidth of 50 kHz

Supported software

LoRaWAN:

- Choice of work mode between Packet_Forwarder and Basic_Station
- Choice of regional parameters
- Channel plan setup
- LBT startup and setup
- Support of one LoRa concentrator
- Receiving statistics

Network

- Setting up LAN using a DHCP server or STATIC
- Activating and configuring firewall
- Setting up interface priority (depending on device model)
- Setting up LTE connection (depending on device model)

System

- Web UI management and SSH connection
- Selecting timezone and NTP source—GNSS, DHCP, list
- Firmware updates